



(19) **United States**

(12) **Patent Application Publication**  
**Yamaya et al.**

(10) **Pub. No.: US 2012/0150017 A1**

(43) **Pub. Date: Jun. 14, 2012**

(54) **OPEN PET/MRI HYBRID MACHINE**

**Publication Classification**

(75) Inventors: **Taiga Yamaya**, Chiba-shi (JP);  
**Hideo Murayama**, Chiba-shi (JP);  
**Takayuki Obata**, Chiba-shi (JP);  
**Ichio Aoki**, Chiba-shi (JP)

(51) **Int. Cl.**  
**A61B 5/055** (2006.01)

(52) **U.S. Cl.** ..... **600/411**

(57) **ABSTRACT**

(73) Assignee: **NATIONAL INSTITUTE OF RADIOLOGICAL SCIENCES**,  
Chiba-shi, Chiba (JP)

A PET/MRI hybrid machine that combines a PET device with an MRI device, includes: an open PET device that has a PET field of view at least part of which is an open space accessible from outside; and an open MRI device that has an MRI field of view at least part of which is an open space accessible from outside, and the open space of the PET field of view and the open space of the MRI field of view are allowed to overlap each other at least in part. This makes it possible to simultaneously measure and image the same open space accessible from outside by the PET device and the MRI device, thereby acquiring functional information and morphological information at the same time.

(21) Appl. No.: **13/255,831**

(22) PCT Filed: **Mar. 12, 2009**

(86) PCT No.: **PCT/JP2009/054780**

§ 371 (c)(1),  
(2), (4) Date: **Feb. 21, 2012**

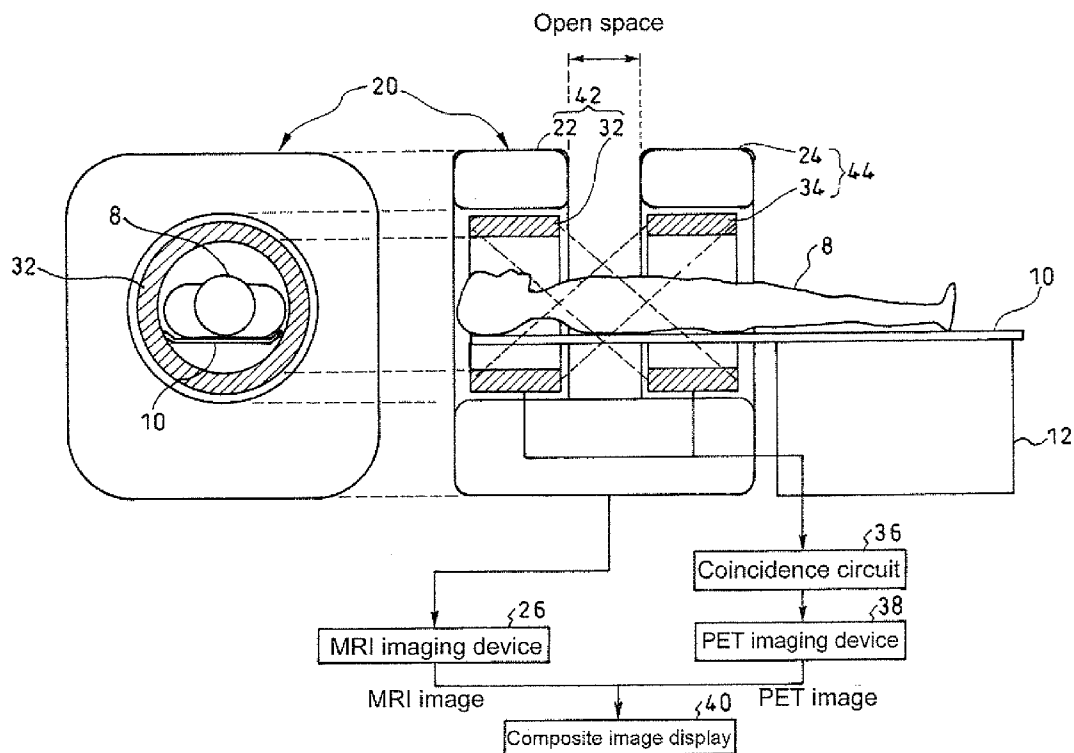

Fig. 1

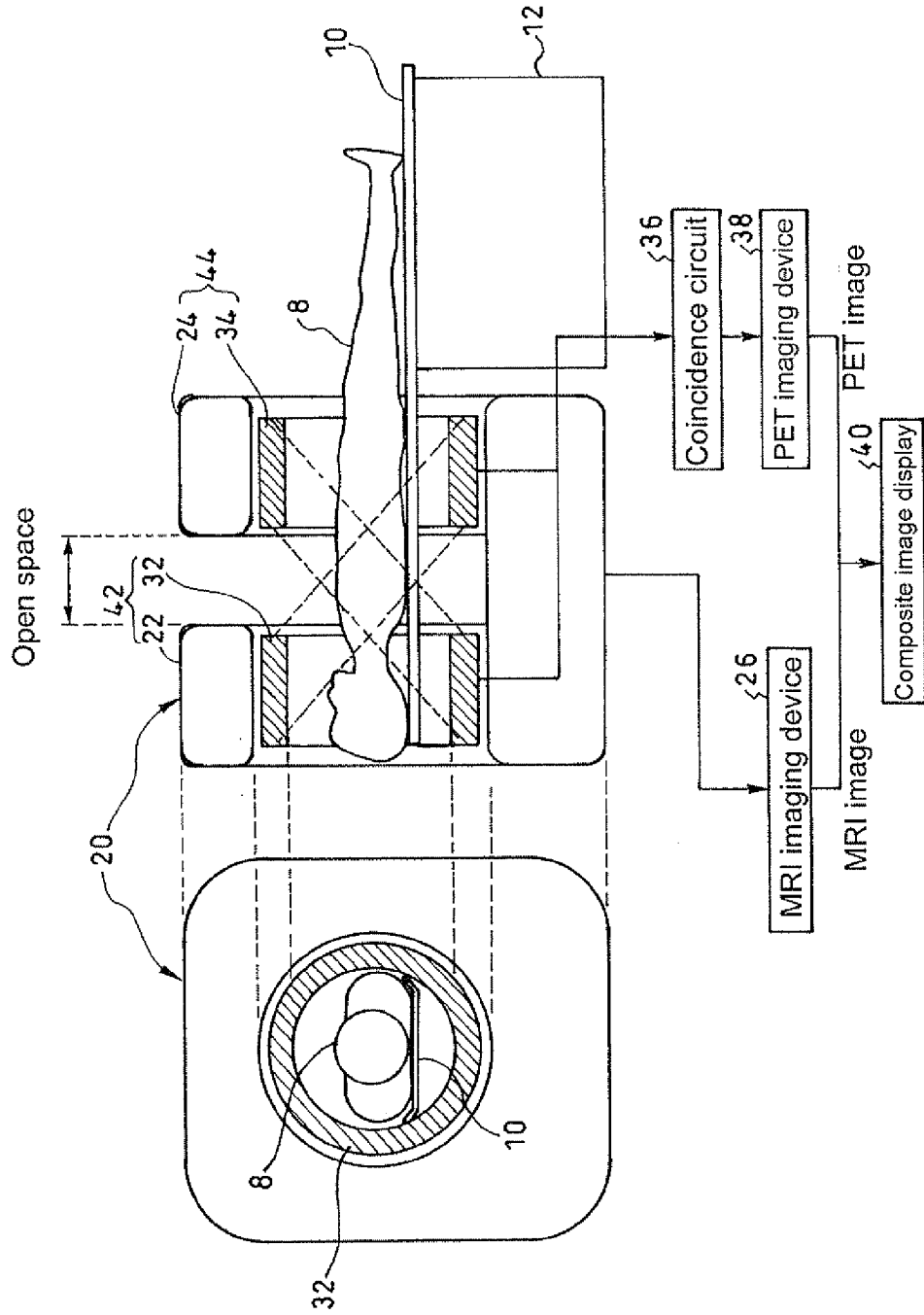

Fig. 2

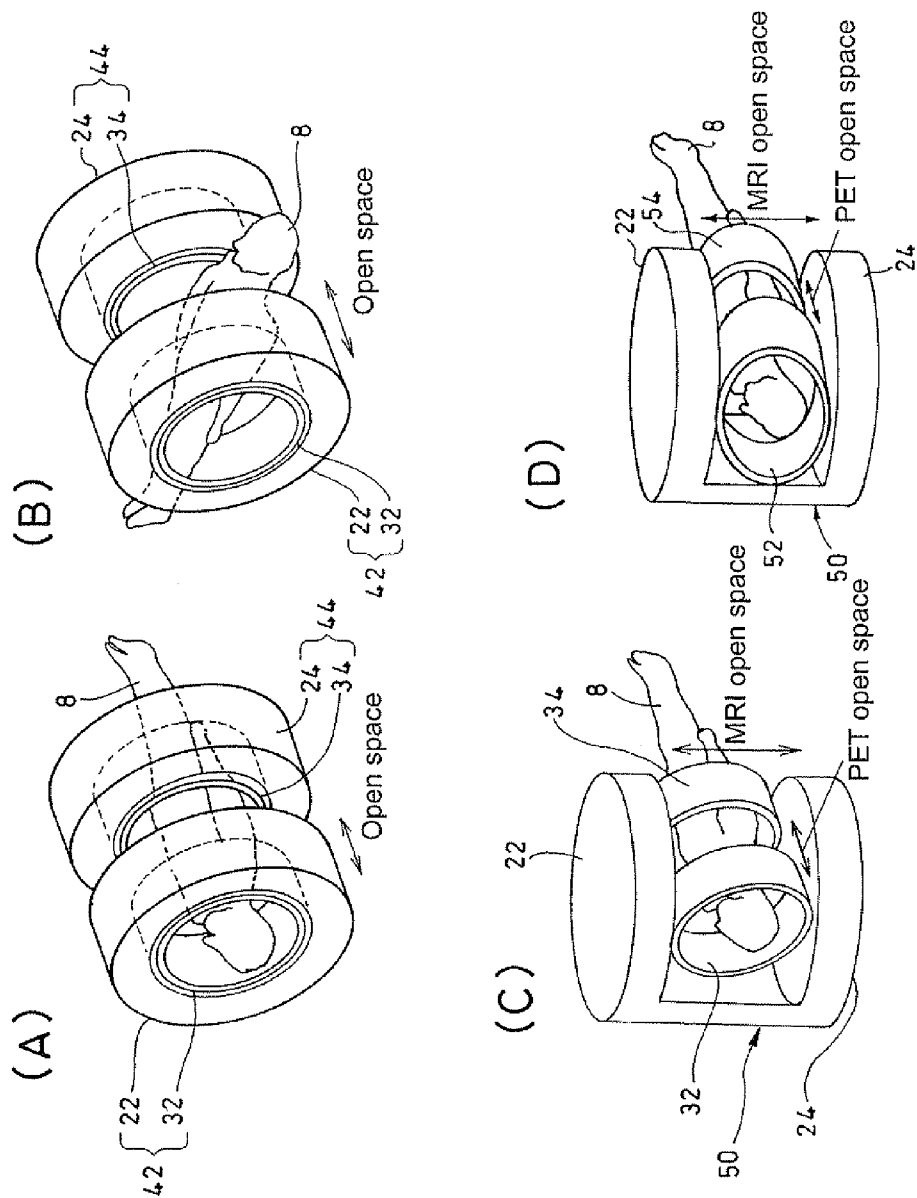

Fig. 3

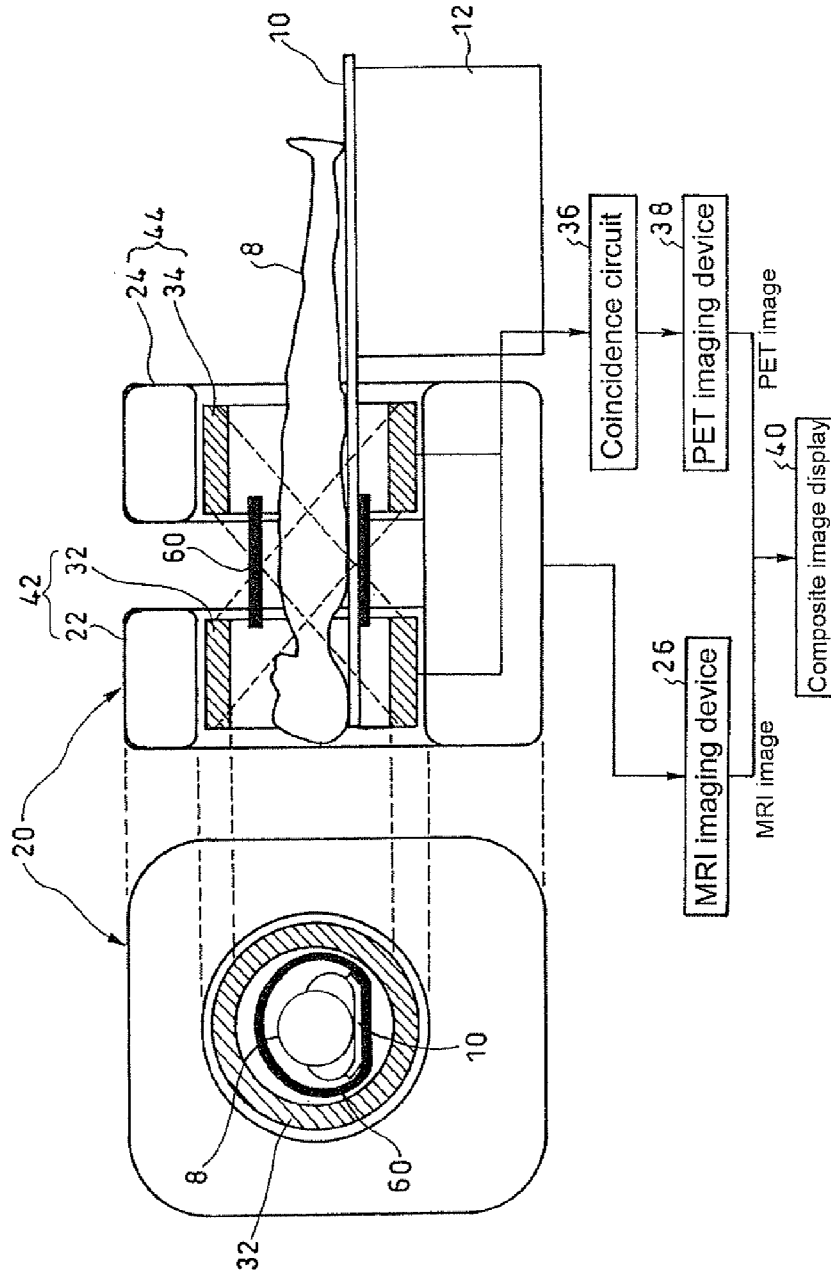

Fig. 4

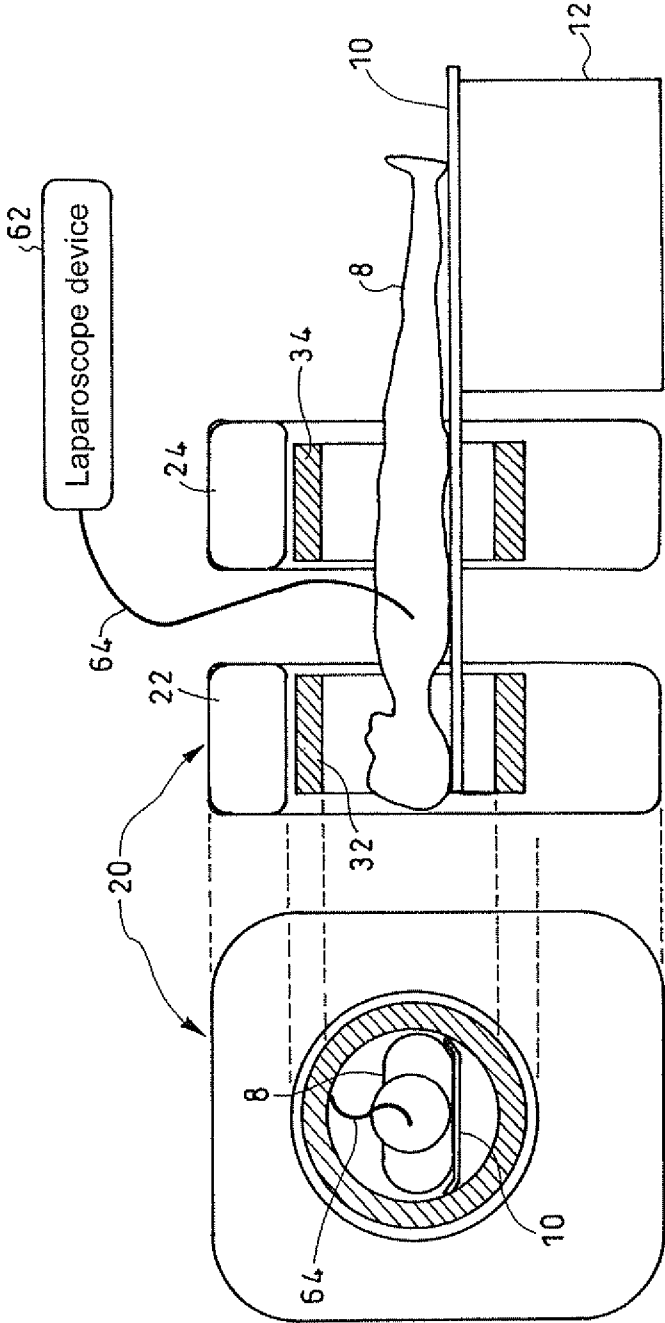

Fig. 5

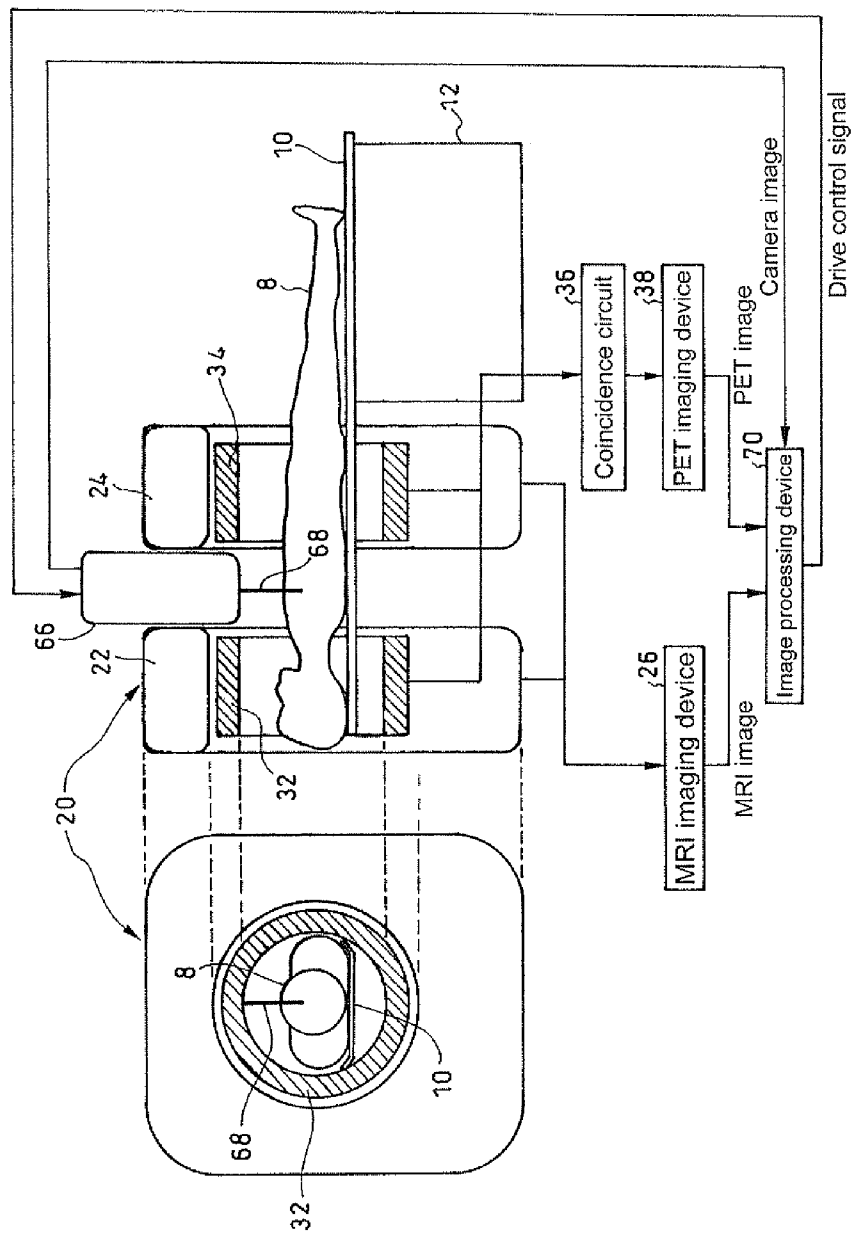

Fig. 6

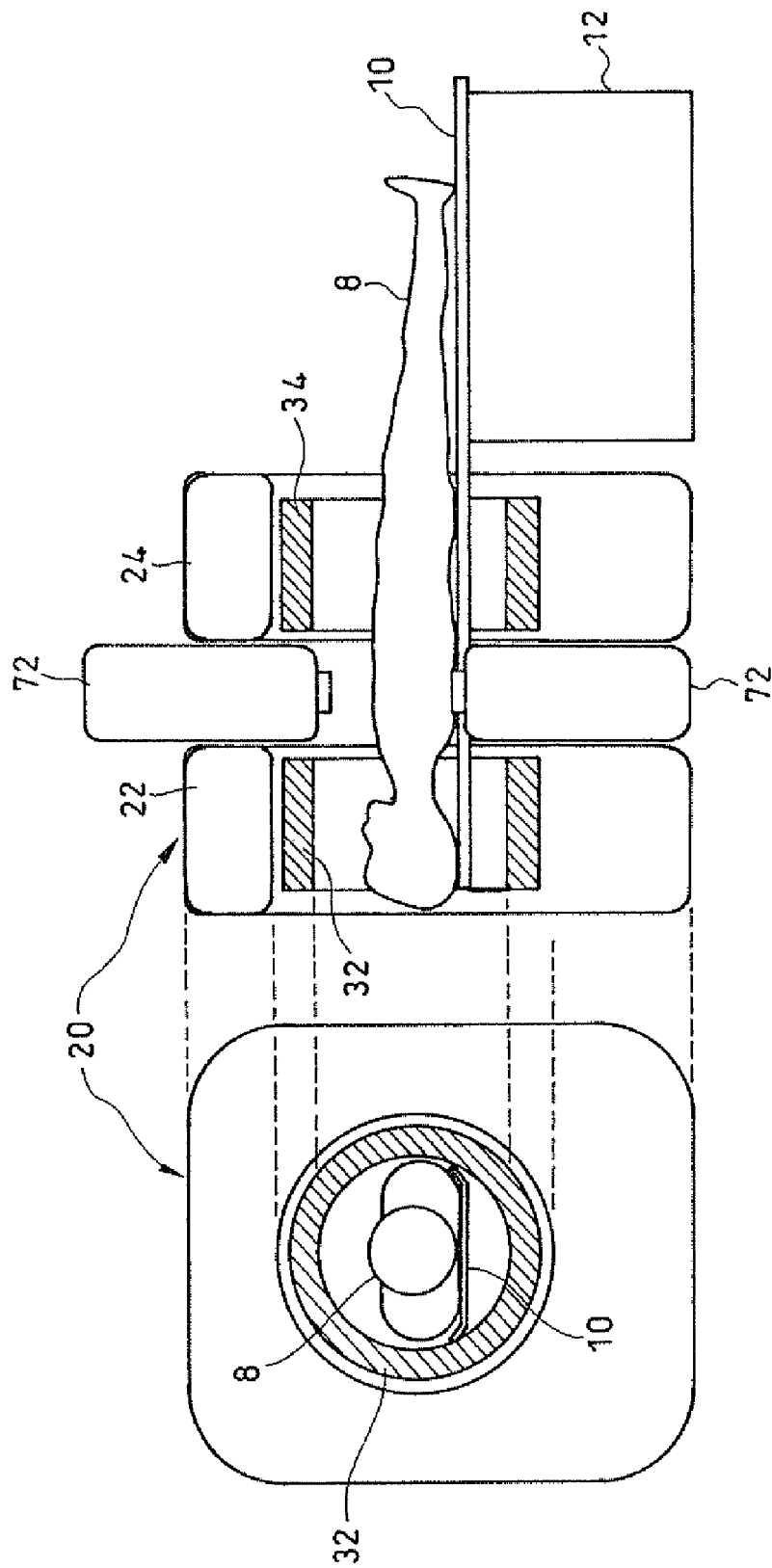

Fig. 7

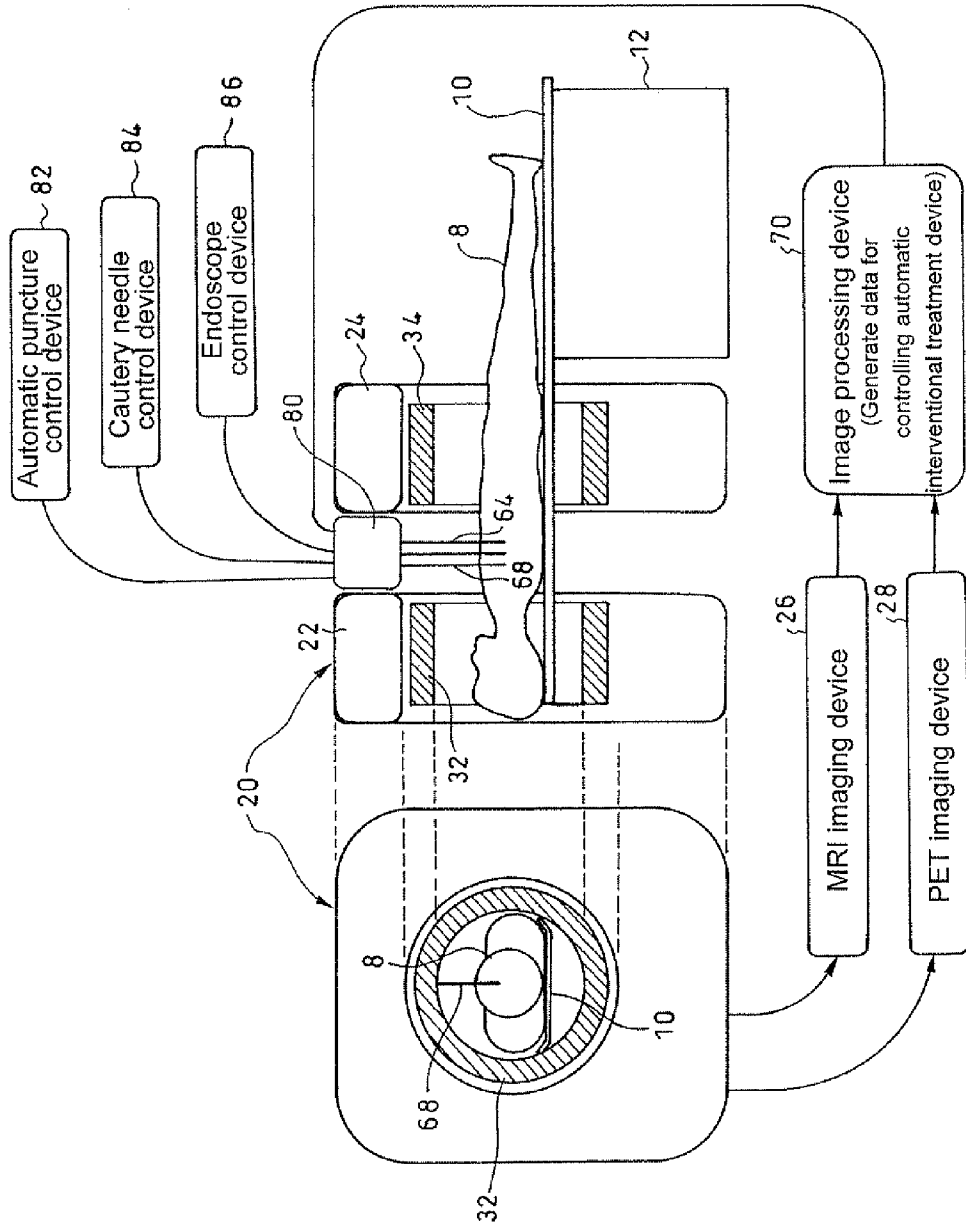



Fig. 8

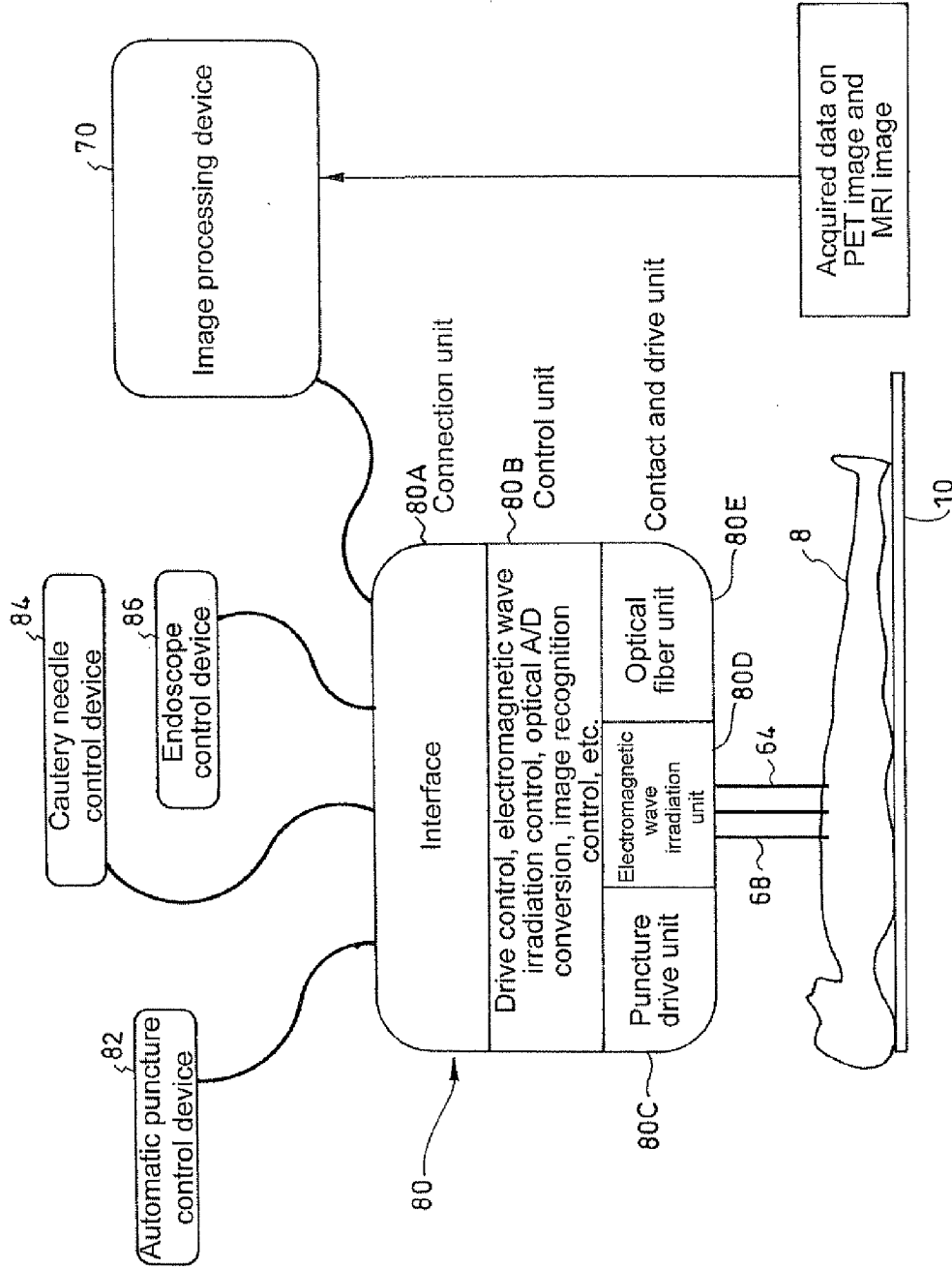

Fig. 9

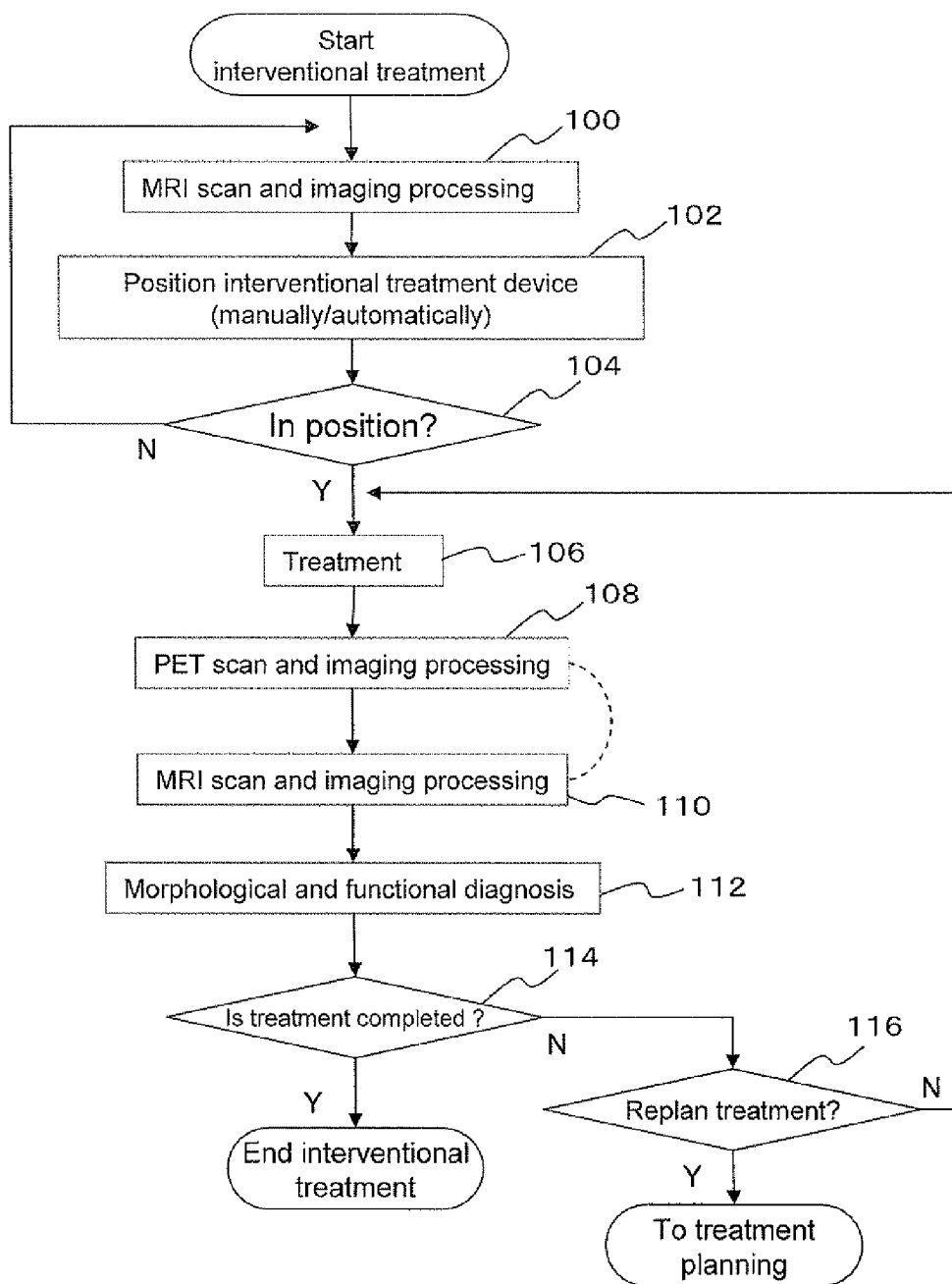

Fig. 10

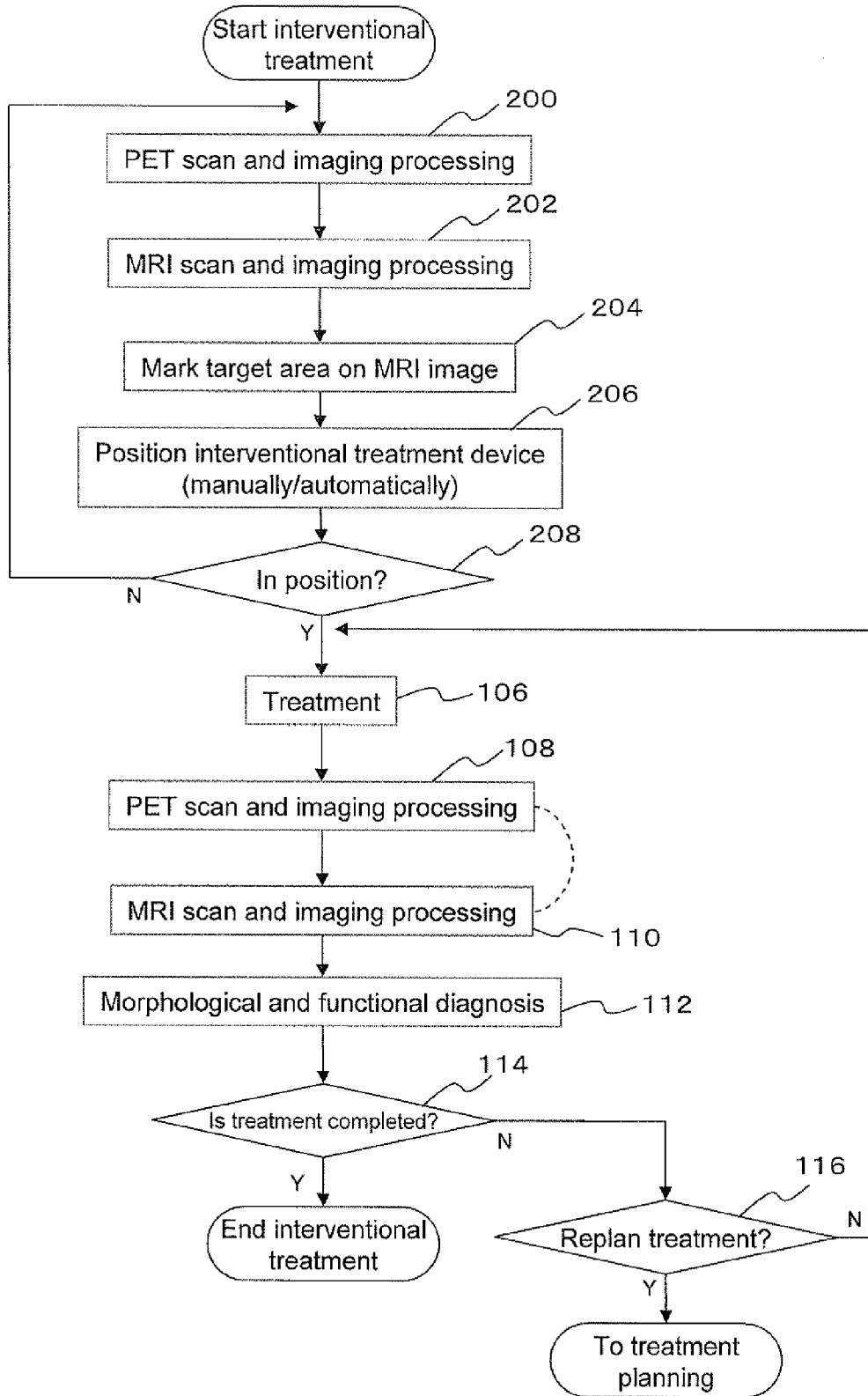
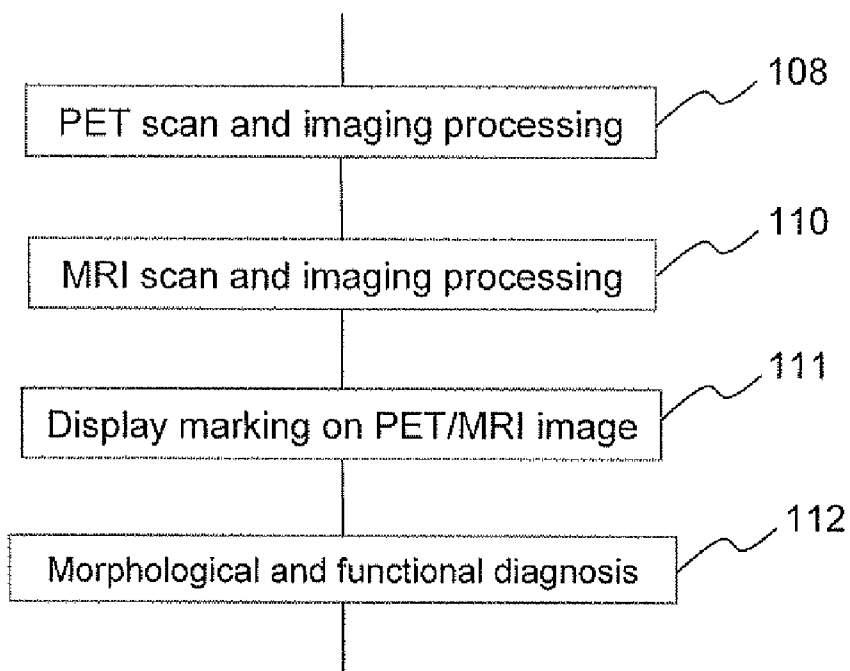

Fig. 11



## OPEN PET/MRI HYBRID MACHINE

### TECHNICAL FIELD

**[0001]** The present invention relates to a PET/MRI hybrid machine that combines a PET device with an MRI device, and more particularly to an open PET/MRI hybrid machine that can simultaneously measure and image the same open space accessible from outside by the PET device and the MRI device, thereby acquiring biological functional information and morphological information at the same time.

### BACKGROUND ART

**[0002]** PET is a method of administering a compound that is labeled with positron-emitting radionuclides and imaging the distribution of the compound in the body as a tomographic image. While X-ray CT or MRI based tomographic images provide morphological information, PET images are referred to as functional images which express biological functional information. For example, PET images are capable of highly sensitive tumor detection though not precise in position. To add accurate positional information to a PET image, it is needed to superpose an X-ray CT image or MRI image, which is precise in position but low in sensitivity and detection power, on the PET image. For efficient superposition and scanning, PET/CT devices have been prevalent that combine a PET device and an X-ray CT device.

**[0003]** Since X-ray CT is typically higher than PET in exposure level, hybrid machines with MRI, which is free from radiation exposure, have been under development. (See Ciprian Catana et al. "Simultaneous Acquisition of Multislice PET and MR Images: Initial Results with a MR-Compatible PET Scanner" *The Journal of Nuclear Medicine*, Vol. 47, No. 12, December 2006 pp 1968-1976.)

**[0004]** Using such a PET/MRI hybrid machine, functional information and morphological information can be integrated to obtain highly-sensitive and accurate positional information. MRI techniques for imaging some biological functions, typified by fMRI, have also been advancing, and such PET/MRI hybrid machines can even acquire a PET-based functional image and an MRI-based functional image simultaneously. In any case, however, the closed field of view imposes a lot of psychological stress on the subject as well as makes interventional treatment difficult.

**[0005]** Meanwhile, open MRI devices have been developed and released that acquire MRI images of an open space. (See Joshua Liliestien et al. "In Vivo Sonography Through an Open MRI Breast Coil to Correlate Sonographic and MRI Findings" *AJR*: 184, March 2005 s49-52, Hiroshi Iseki et al. "Intelligent Operating Theater Using Intraoperative Open-MRI" *Magnetic Resonance in Medical Sciences*, Vol. 4, No. 3, p. 129-136, 2005, Junta Harada et al. "initial Experience of Percutaneous Renal Cryosurgery under the Guidance of a Horizontal Open MRI System" *Radiation Medicine*, Vol. 19, No. 6, 291-296 p.p., 2001, DiMaio S P et al. "Robot-assisted needle placement in open MRI: system architecture, integration and validation" *Comput Aided Surg.* 2007 January; 12 (1): 15-24, DiMaio S P et al. "Robot-assisted needle placement in open MRI: system architecture, integration and validation" *Stud Health Technol Inform.* 2006; 119: 126-31.)

**[0006]** Such open MRI devices are used to administer treatments under MRI guidance, making use of MRI's high spatial resolution and noninvasiveness. Conventionally, the only modality capable of imaging an open space in a tomographic

device has been MRI, whereas the applicant has proposed an open PET device that allows PET diagnosis even during treatment. (Taiga Yamaya, Taku Inaniwa, Shinichi Minohara, Eiji Yoshida, Naoko Inadame, Fumihiko Nishikido, Kengo Shibuya, Chih Fung Lam and Hideo Murayama, "A proposal of an open PET geometry," *Phy. Med. Biol.*, 53, pp. 757-773, 2008.) According to the technology, two separate detector rings are arranged apart in the direction of the body axis, and radiations are detected from lines of coincidence between the rings. This allows imaging of the open space between the detection rings.

**[0007]** The PET device, however, has had a problem that the PET device by itself is not capable of acquiring morphological information.

### DISCLOSURE OF THE INVENTION

**[0008]** The present invention has been achieved in order to solve the foregoing conventional problems, and it is an object thereof to make it possible to simultaneously measure and image the same open space accessible from outside by PET and MRI, thereby acquiring functional information and morphological information at the same time.

**[0009]** The foregoing object of the present invention has been achieved by the provision of a PET/MRI hybrid machine that combines a PET device with an MRI device, including: an open PET device that has a PET field of view at least part of which is an open space accessible from outside; and an open MRI device that has an MRI field of view at least part of which is an open space accessible from outside, the open space of the PET field of view and the open space of the MRI field of view being allowed to overlap each other at least in part.

**[0010]** Here, two composite rings may be opposed to each other with an open space accessible from outside therebetween so that the PET field of view and the MRI field of view are allowed to overlap each other in the open space, the two composite rings each including one of detector rings of the open PET device arranged in one of magnets (i.e., coils creating static magnetic field) of the open MRI device.

**[0011]** An MRI RF coil may be fixed to or movably arranged on a bed that is insertable into the composite rings, and the RF coil and/or the bed may be moved so that the RF coil enters the open space to allow the PET field of view and the MRI field of view to overlap each other.

**[0012]** The RF coil may be moved with respect to the bed and in a longitudinal direction of the bed so as to adjust the MRI field of view in position.

**[0013]** A working unit may be arranged in the open space.

**[0014]** The working unit may be retractably arranged in the open space.

**[0015]** The working unit may be any of an image acquisition unit, an irradiation device, and a general-purpose interventional treatment unit, or a combination thereof.

**[0016]** The general-purpose interventional treatment unit may include at least any one of an automatic puncture device, an electromagnetic cautery needle, and a laparoscope.

**[0017]** The same field, of view may be simultaneously imaged in three or more modalities.

**[0018]** A PET and/or MRI image(s) may be acquired at least once both before and after operation of the working unit.

**[0019]** A marking of a target position identified by a PET image that is acquired before operation of the working unit may be put on a simultaneously-acquired MRI image, and the

marking may be displayed on a PET and/or MRI image(s) acquired after the operation of the working unit.

**[0020]** According to the present invention, it becomes possible to simultaneously measure and image the same open space accessible from outside by the PET device and the MRI device, thereby acquiring functional information and morphological information at the same time. This can provide a highly useful open space.

**[0021]** For example, treatment and PET/MRI diagnosis can be combined to check the position by MRI, diagnose biological functions by PET, and administer a real-time interventional treatment at the same time. Aside from conventional radiation therapy, treatment methods that can be combined include an ultrasonic cautery needle, puncture, a puncture cautery needle, ultrasonic-based sonodynamic therapy (SDT), laser-based photodynamic therapy (PDT), chemotherapy, radiation triggering, and RE triggering.

**[0022]** Performing diagnosis on the head in a PET/MRI device with a long tunnel-like patient port imposes high psychological stress on the subject. According to the present invention, the simultaneous PET and MRI measurements of the open space can significantly reduce the stress on the subject.

**[0023]** Open-type devices provide doctors and operators easy access to the subject, allowing easy condition check. In particular, in the field of brain researches, responses to visual and other stimulations are sometimes inspected by PET or MRI. The presence of the open space facilitates experiments.

**[0024]** Moreover, the open space allows installation of a third diagnostic device and the like, whereby the same field of view can be simultaneously imaged in three or more modalities. Examples of the third diagnostic device include an ultrasonic device, a SPECT device, a fluorescent imager, an optical camera, and an optical CT device.

#### BRIEF DESCRIPTION OF THE DRAWINGS

**[0025]** FIG. 1 is a block diagram showing the overall configuration of a first embodiment of the present invention, including a side view and a front view thereof;

**[0026]** FIG. 2 is a perspective view showing the configuration of essential parts of the first embodiment and modifications thereof;

**[0027]** FIG. 3 is a block diagram showing the overall configuration of a second embodiment of the present invention, including a side view and a front view thereof;

**[0028]** FIG. 4 includes a side view and a front view showing the configuration of essential parts of a third embodiment of the present invention;

**[0029]** FIG. 5 is a block diagram showing the configuration of essential parts of a fourth embodiment of the present invention, including a side view and a front view thereof;

**[0030]** FIG. 6 includes a side view and a front view showing the configuration of essential parts of a fifth embodiment of the present invention;

**[0031]** FIG. 7 is a block diagram showing the overall configuration of a sixth embodiment of the present invention, including a side view and a front view thereof;

**[0032]** FIG. 8 is a block diagram showing the configuration of a general-purpose interventional treatment unit according to the sixth embodiment;

**[0033]** FIG. 9 is a flowchart showing an example of a diagnosis/treatment procedure according to the present invention;

**[0034]** FIG. 10 is a flowchart showing another example of the diagnosis/treatment procedure according to the present invention; and

**[0035]** FIG. 11 is a flowchart showing a modification of the diagnosis/treatment procedure according to the present invention.

#### BEST MODE FOR CARRYING OUT THE INVENTION

**[0036]** Hereinafter, embodiments of the present invention will be described in detail with reference to the drawings.

**[0037]** As shown in FIG. 1, a first embodiment of the present invention includes an open MRI device **20** of so-called doubled doughnut type, having two magnets **22** and **24** which are arranged apart in the direction of the body axis of a subject **8**. Antimagnetic PET detector rings **32** and **34** are arranged in patient ports on respective sides to constitute composite rings **42** and **44**. The space between the two separated, opposed composite rings **42** and **44** is the overlapping open space of MRI and PET. In the diagram, **12** represents a pedestal of a bed **10**, **26** represents an MRI imaging device, **36** represents a coincidence circuit for PET measurement, **38** represents a PET imaging device, and **40** represents a composite image display which displays a morphological image obtained by the MRI imaging device **26** and a functional image obtained by the PET imaging device **38** in a superposed manner.

**[0038]** With such a configuration, radiations are measured from lines of coincidence between the PET detector rings **32** and **34**, whereby the same open space as that of the MRI device can be imaged by PET. Working units such as an image acquisition unit, an irradiation device, and a general-purpose interventional treatment unit may be arranged in the open space. Coincidence measurement by the PET detector ring **32** itself and coincidence measurement by the PET detector ring **34** itself can be combined to acquire PET images over a wide field of view in the direction of the body axis, including the open space.

**[0039]** In FIG. 1, the composite rings **42** and **44** including the PET detector rings **32** and **34** arranged in the magnets **22** and **24**, respectively, are arranged apart in the direction of the body axis of the subject **8** as shown in FIG. 2(A). However, the system configuration is not limited thereto. As shown in FIG. 2(B), the opposed composite rings **42** and **44** may be arranged apart in a direction orthogonal to the body axis of the subject. As shown in FIG. 2(C), the circular PET detector rings **32** and **34** may be arranged apart in the direction of the body axis of the subject **8** in the open space of a hamburger-shaped open MRI device **50**. Alternatively, as shown in FIG. 2(D), elliptical PET detector rings **52** and **54** may be arranged apart in the direction of the body axis of the subject **8** in the open space of the hamburger-shaped open MRI device **50**.

**[0040]** According to the example of FIG. 2(A), the head of the subject is easily accessible. According to the example of FIG. 2(D), the distance between the magnets **22** and **24** of the MRI device **50** can be reduced for device miniaturization.

**[0041]** Next, a second embodiment of the present invention will be described in detail with reference to FIG. 3.

**[0042]** In the present embodiment, an RF coil **60** for MRI is fixed to or movably arranged on the bed **10**. The RF coil **60** and/or the bed **10** is/are moved in the direction of the body axis of the subject **8** so that the RE coil **60** enters the open space to make the PET field of view and the MRI field of view overlap each other. The RE coil typically has a circular cylin-

dricul frame structure to surround the affected area. The RF coil usually has a lot of openings and will not interfere with access to the affected area.

**[0043]** According to the present embodiment, the RF coil **60** and/or the bed **10** can be moved in the body axis of the subject **8** to adjust the field of view of the MRI image in position.

**[0044]** FIG. **4** shows an example where an inspection tube **64** of a laparoscope device **62** is inserted into the open space as a working unit and laparoscopic inspection/treatment is administered to the subject **8** according to the foregoing first embodiment.

**[0045]** Laparoscopic or endoscopic inspections and treatments refer to inspections and associated treatments using a laparoscope or angioscope, where a small cut is made in the skin or the like to insert the inspection tube **64**, and inspections and associated treatments using an endoscope, where the inspection tube **64** is inserted through an aperture such as nasal and oral cavities. Aside from inspections and treatments that are manually performed by the inspector, inspections and associated treatments that are automatically or semiautomatically performed by mechanical means may also be included.

**[0046]** FIG. **5** shows an example where a needle **68** of an automatic puncture device **66** as a working unit is inserted into the subject **8** through the open space, similarly using the first embodiment.

**[0047]** Puncture inspections and treatments refer to inspections and associated treatments that involve inserting an inspection tube or treatment tool having the shape of a needle **68** through the skin or the like. Puncture inspections and treatments include biopsy, tumor cauterization, local administration of anti-tumor agents, and radio-wave therapy. Aside from inspections and treatments that are manually performed by the inspector, inspections and associated treatments that are automatically or semiautomatically performed by mechanical means may also be included.

**[0048]** In the example of FIG. **5**, the automatic puncture device **66** is fixed to a position where the open spaces of both MRI and PET coincide with each other. The automatic puncture device **66** includes a not-shown digital video camera, lighting, a driver of the needle **68**, a liquid medicine injection device, an electromagnetic heating device, and a tissue removal device (biopsy).

**[0049]** MRI images obtained by the MRI device **20**, PET images obtained by the PET device (**32** and **34**), and pictures from the camera installed in the automatic puncture device **66** are transmitted to an image processing device **70**, and the driver is controlled to insert the needle automatically and accurately into the intended area in the living body. Here, the three-dimensional position for the needle tip to reach is grasped and precisely controlled by using anatomical image information, angiographic image information, temperature image information, and water molecule diffusion image information from MRI, tumor position image information and malignancy image information from PET, skin surface insert position information and body tilt information from the digital video camera, etc.

**[0050]** Treatments with liquid medicines, electromagnetic radiation, and the like are administered from the tip of the needle **68** inserted in the subject **8** if needed. Or, necessary tissue may be removed. The treatment result or the treatment based on the removed tissue is imaged and processed by MRI and PET again, and further treatment is repeated if necessary.

**[0051]** It should be appreciated that the automatic puncture device **66** may be an automatic biopsy device, an automatic surgery device, and the like. Here, treatments by surgery refer to various surgical inspections and surgical treatments that involve cutting the skin or the like. Aside from inspections and treatments that are manually performed by the operator, inspections and associated treatments that are automatically or semiautomatically performed by mechanical means may also be included.

**[0052]** Such treatments are possible because both the PET and MRI are open.

**[0053]** FIG. **6** shows an example where an image acquisition unit and an irradiation device **72** as working units are inserted into the open space to acquire various images or perform irradiation, using the foregoing first embodiment.

**[0054]** A plurality of conformation radiotherapy techniques involving radiation treatment on a selected tumor (such as heavy particle beam radiation therapy, proton beam radiation therapy, and IMRT) have been developed and receiving attention recently. Such techniques can intensively irradiate the affected area while suppressing damage to normal areas, whereas the irradiation field needs to be set accurately.

**[0055]** The open PET/MRI according to the present invention enables accurate checking of tumor margins by MRI when making a final treatment plan immediately before irradiation. Grasping low oxygen regions and active regions in the tumor by PET allows fine adjustments to the dose balance in the irradiated area. Conventionally, a treatment plan has been made by using CT or the like on a different day, in which case detailed information is not available and there is a risk of misalignment.

**[0056]** With the open PET/MRI, whether the actual irradiation field is set according to the treatment plan can be checked even during irradiation based on certain MRI measurements, PET ligands, and PET auto-radioactivation measurements. This allows quick irradiation assessment. Conventionally, it has been possible to predict radiation damage that appears a few months later.

**[0057]** Moreover, conformation radiotherapy often needs an irradiation angle as wide as 360°. The design of the open PET/MRI is right suited to such uses.

**[0058]** An image acquisition unit may be used to acquire images of the surface of the living body or inside the living body. The image acquisition unit may include visible light cameras and videos, optical measurements using visible light, infrared or near infrared cameras, X-ray CT, simple X-ray images, X-ray video cameras, fluorescent or luminescence imaging, optical coherence tomography, ultrasonic image probes, laser scanners, and MRI radio frequency coils.

**[0059]** Radiation or heat treatments refer to inspections and associated treatments that involve applying electromagnetic waves, sonic waves, ultrasonic waves, vibrations, heat, or the like from the surface of the skin or from a remote area. Inspections and treatments that involve irradiation with infrared rays, near infrared rays, visible light, X-rays, gamma rays, various types of particle beams, sonic waves, ultrasonic waves, vibrations, heat, and the like may be included. Medication and inspections to be triggered by such irradiations may also be included.

**[0060]** FIG. **7** shows an example where a general-purpose interventional treatment unit **80** as a working unit is arranged in the open space according to the first embodiment. The general-purpose interventional treatment unit **80** is connected

with an automatic puncture control device **82** as well as a cautery needle control device **84**, an endoscope control device **86**, and the like. In the example, the image processing device **70** generates control data for the general-purpose interventional treatment unit **80** and performs feedback control on the inspection tube **64**, the needle **68**, etc.

**[0061]** FIG. **8** is a block diagram showing the control of FIG. **7** in detail. The general-purpose interventional treatment unit **80** includes: a connection unit **80A** which serves as an interface with the automatic puncture control device **82**, the cautery needle control device **84**, the endoscope control device **86**, and the like; a control unit **80B** which performs drive control, electromagnetic wave irradiation control, optical A/D conversion, image recognition control, and the like; and connection and drive units such as a puncture drive unit **800**, an electromagnetic wave irradiation unit **800**, and an optical fiber unit **80E**.

**[0062]** FIG. **9** is a flowchart showing the procedure in an example where positioning is performed by using MRI images (steps **100**, **102**, and **104**). After treatment (step **106**), PET and/or MRI diagnosis (step **108**, **110**, and **112**) is performed and an instant evaluation is made on the treatment result (step **114**).

**[0063]** FIG. **10** is a flowchart showing one example of the procedure for situations where a cancer position is identified by FDG-PET before treatment, followed by cancer treatment. PET needs a time frame longer than that of MRI. In the example, a target position is identified by using a PET image (step **200**), and its marking is put (step **204**) on an MRI image that is simultaneously acquired (step **202**). Under the MRI guidance, the interventional treatment device is positioned to the target (steps **206** and **208**). After treatment (step **106**), PET and/or MRI image diagnosis (steps **108**, **110**, and **112**) is performed and an instant evaluation is made on the treatment result (step **114**).

**[0064]** FIG. **11** is a flowchart where a step of displaying the marking put in step **204** on a PET and/or MRI image (step **111**) is added to between the step of making PET and/or MRI image diagnosis (step **108** and **110**) and the morphological and functional diagnosis step (step **112**) of FIG. **10**. This makes it possible to accurately check changes in the same area that is imaged at different times.

**[0065]** In any of FIGS. **9** to **11**, the PET scan and imaging processing (step **108**, **200**) and the MRI scan and imaging processing (step **110**, **202**) may be performed in reverse order. In FIG. **9**, the MRI scan and imaging processing **110** may be omitted to make a diagnosis based only on the PET image in step **108**. In FIG. **10**, either one of the PET scan and imaging processing **108** and the MRI scan and imaging processing **110** may be omitted.

**[0066]** If in step **114** the treatment is determined not to be completed yet, then in step **116**, determination is made as to whether treatment needs to be replanned. If not, the processing returns to step **106** to repeat the treatment according to the same treatment plan. If treatment needs to be replanned, a treatment plan is made again.

**[0067]** While the foregoing description has dealt with the cases where the number of PET detector rings is two, the number of PET detector rings may be three or more.

**[0068]** A television, computer, or other display for visualization, audio equipment, an odor generation device or tube, a skin irritating device, a taste stimulating device, and devices for acquiring and analyzing various types of biological information including pulses, blood pressure, an electrocardio-

gram, respiration, and blood components may be arranged in the open space for associated treatment.

**[0069]** Working units may be retractably arranged in the open space by using existing technologies. Such working units may be retracted when not needed in operation, whereby the open space is opened so as to be fully accessible from outside.

#### INDUSTRIAL APPLICABILITY

**[0070]** The present invention is applicable to PET/MRI hybrid machines in general that combine a PET device and an MRI device, whereby functional information and morphological information can be simultaneously acquired from the same open space that is accessible from outside. This makes it possible to provide a highly useful open space suited to treatment and the like.

**1.** A PET/MRI hybrid machine that combines a PET device with an MRI device, comprising:

an open PET device that has a PET field of view at least part of which is an open space accessible from outside; and an open MRI device that has an MRI field of view at least part of which is an open space accessible from outside, wherein

the open space of the PET field of view and the open space of the MRI field of view are allowed to overlap each other at least in part.

**2.** The PET/MRI hybrid machine according to claim **1**, wherein two composite rings are opposed to each other with an open space accessible from outside therebetween so that the PET field of view and the MRI field of view are allowed to overlap each other in the open space, the two composite rings each including one of detector rings of the open PET device arranged in one of coils creating static magnetic field of the open MRI device.

**3.** The PET/MRI hybrid machine according to claim **2**, wherein an MRI RF coil is fixed to or movably arranged on a bed that is insertable into the composite rings, and the RF coil and/or the bed are moved so that the RF coil enters the open space to allow the PET field of view and the MRI field of view to overlap each other.

**4.** The PET/MRI hybrid machine according to claim **3**, wherein the RF coil is moved with respect to the bed and in a longitudinal direction of the bed so as to adjust the MRI field of view in position.

**5.** The PET/MRI hybrid machine according to claim **1**, wherein a working unit is arranged in the open space.

**6.** The PET/MRI hybrid machine according to claim **5**, wherein the working unit is retractably arranged in the open space.

**7.** The PET/MRI hybrid machine according to claim **5**, wherein the working unit is any of an image acquisition unit, an irradiation device, and a general-purpose interventional treatment unit, or a combination thereof.

**8.** The PET/MRI hybrid machine according to claim **7**, wherein the general-purpose interventional treatment unit includes at least any one of an automatic puncture device, an electromagnetic cautery needle, and a laparoscope.

**9.** The PET/MRI hybrid machine according to claim **5**, wherein the same field of view is simultaneously imaged in three or more modalities.

**10.** The PET/MRI hybrid machine according to claim **5**, wherein a PET and/or MRI image is acquired at least once both before and after operation of the working unit.



11. The PET/MRI hybrid machine according to claim 5, wherein a marking of a target position identified by a PET image that is acquired before operation of the working unit is put on a simultaneously-acquired MRI image, and the mark-

ing is displayed on a PET and/or MRI image acquired after the operation of the working unit.

\* \* \* \* \*